

CCS Technical Documentation

RH-17 Series Transceivers

System Module

Contents

	Page No
Introduction	5
Operational Modes	5
Engine Module	7
Environmental Specifications	7
Temperature Conditions	7
Baseband Module.....	8
UEM	8
UEM Introduction	8
Regulators.....	8
RF Interface.....	10
Charging Control.....	10
Digital Interface.....	10
Audio Codec.....	10
UI Drivers.....	10
AD Converters.....	10
BB-RF Interface Connections	11
UPP	14
UPP Introduction.....	14
Blocks.....	14
Flash Memory	15
Introduction	15
User Interface Hardware	15
LCD	15
Introduction	15
Interface.....	15
Keyboard	15
Introduction	15
Power Key	15
Keys.....	16
Lights	16
Introduction	16
Interfaces	16
Technical Information	16
Vibra	16
Introduction	16
Interfaces	16
Audio Hardware	17
Earpiece	17
Introduction	17
Microphone	17
Introduction	17
Battery	17
Phone Battery	17
Introduction	17
Interface.....	17
Battery Connector	18
Accessories Interface	19

System connector	19
Introduction	19
Interface.....	19
TTY/TTD and Universal Headset Jack	23
Charger IF	23
Introduction	23
Interface.....	23
Test Interfaces	24
Production Test Pattern	24
Other Test Points	24
EMC	26
General	26
BB Component and Control I/O Line Protection	26
Keyboard Lines	26
PWB	26
LCD.....	26
Microphone	26
EARP.....	26
Bottom Connector Lines	26
Battery Connector Lines.....	26
M-bus F-bus	27
General Information About Testing	27
Phone operating modes	27
RF Module	27
Requirements	27
Temperature Conditions	27
Main Technical Characteristics.....	28
Environmental Specifications	28
Normal and extreme voltages.....	28
Voltage range:	28
Temperature conditions:	28
Antenna	28
Transmitter	29
Synthesizer	30
UHF LO Synthesizer.....	31
Receiver	33
GE / CE Interface.....	34

Transceiver RH-17

Introduction

The RH-17 is available as either CDMA 800 and AMPS or CDMA 800 only, depending on model. It supports the new CDMA 1XRTT standard air interface.

Advanced messaging features include SMS (MO/MT), Instant Messaging, Nokia 'Chat' and Smart Messaging (ring tones, graphics, images, and animations).

The standard internal battery (BL-5C) provides users with up to 2:40 hours of talk time (digital) and 1:45 hours of talk time (analog). Standby time is 280 hours (digital) and 25 hours (analog).

Two antennas are used – internal; external, extendable silver "whip". When the whip antenna is in, only the internal antenna is active. When the whip is retracted, both antennas are active. Access to test the cellular engine is possible once the A cover is removed.

Operational Modes

There are several different operational modes: Modes have different states controlled by the cellular SW. Some examples are: Idle State (on ACCH), Camping (on DCCH), Scanning, Conversation, No Service Power Save (NSPS) *previously OOR = Out of Range*.

In the power-off mode, only the circuits needed for power-up are active.

In the idle mode, circuits are powered down and only the sleep clock is running.

In the active mode, all the circuits are supplied with power, although some parts might be in idle state part of the time.

The charge mode is effective in parallel with all previous modes. The charge mode itself consists of two different states; *i.e.*, the fast charge and the maintenance mode.

The local and test modes are used for alignment and testing.

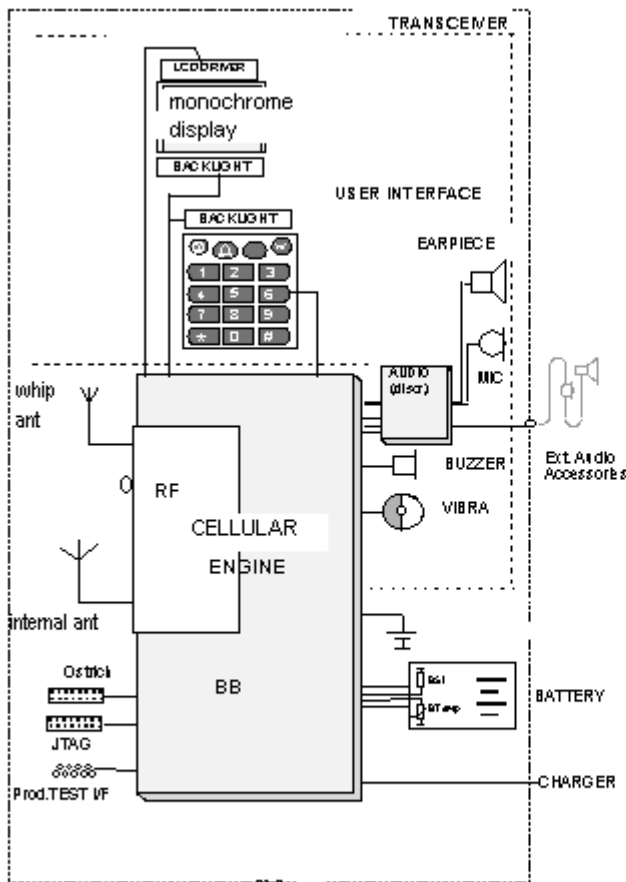

Figure 1: Interconnecting Diagram

Engine Module

Environmental Specifications

Normal and extreme voltages

Voltage range:

- nominal battery voltage: 3.6 V
- maximum battery voltage: 4.2 V
- minimum battery voltage: 3.2 V

Temperature Conditions

Temperature range:

- ambient temperature: -30...+ 60° C
- PWB temperature: -30...+85° C

Baseband Module

The core part of the RH-17 baseband module consists of three ASICs—UEM and UPP—and flash memory. The following sections describe these parts.

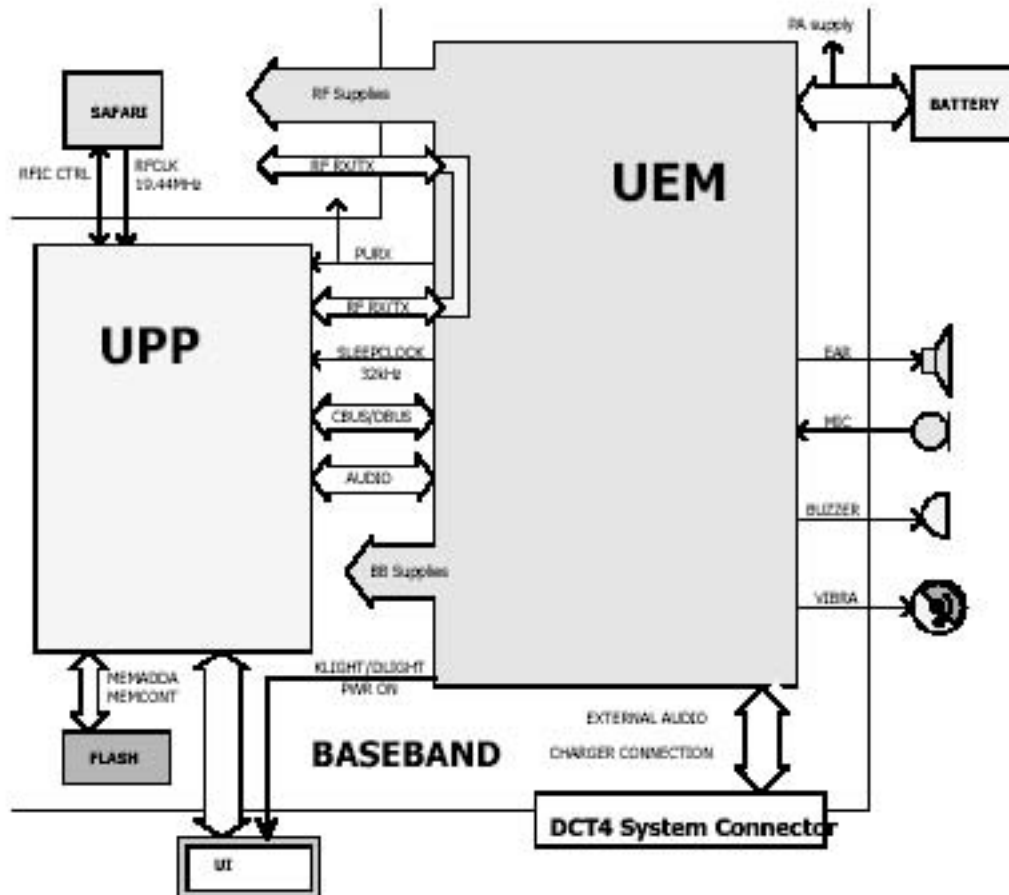

UEM

UEM Introduction

UEM is the Universal Energy Management IC for DCT4 digital handportable phones. In addition to energy management, it performs all the baseband mixed-signal functions.

Most of UEM pins have 2kV ESD protection. Those signals that are considered to be exposed more easily to ESD have 8kV protection inside UEM. Such signals are all audio signals, headset signals, BSI, Btemp, Fbus, and Mbus signals.

Regulators

UEM has six regulators for baseband power supplies and seven regulators for RF power supplies. VR1 regulator has two outputs VR1a and VR1b.

Bypass capacitor (1uF) is required for each regulator output to ensure stability.

Reference voltages for regulators require external 1uF capacitors. Vref25RF is reference voltage for VR2 regulator; Vref25BB is reference voltage for VANA, VFLASH1, VFLASH2, VR1 regulators; Vref278 is reference voltage for VR3, VR4, VR5, VR6, VR7 regulators;

VrefRF01 is reference voltage for VIO, VCORE, VSIM regulators, and for RF.

BB	RF
VANA: 2.78Vtyp 80mAmax	VR1a:4.75V 12mAmax VR1b:4.75V 12mAmax
Vflash1: 2.78Vtyp 70mAmax	
Vflash2: 2.78Vtyp 40mAmax	VR2:2.78V 100mAmax
VSim: 1.8/3.0V 25mAmax	VR3:2.78V 20mA
VIO: 1.8Vtyp 150mAmax	VR4: 2.78V 50mAmax
Vcore: 1.0-1.8V 200mAmax	VR5: 2.78V 50mAmax
	VR6: 2.78V 50mAmax
	VR7: 2.78V 45mAmax

VANA regulator supplies internal and external analog circuitry of BB. It's disabled in sleep mode.

Vflash1 regulator supplies LCD and digital parts of UEM ASIC. It is enabled during startup and goes to low Iq-mode in sleep mode.

Vflash2 regulator is not used on RH-17. It could be enabled/disabled through writing register and default is off.

VIO regulator supplies both external and internal logic circuitries. It's used by LCD, flash, Robin, Batman, and UPP. Regulator goes in to low Iq-mode in sleep mode.

VCORE regulator supplies DSP and Core part of UPP. Voltage is programmable and the startup default is 1.5V. Regulator goes to low Iq-mode in sleep mode.

VR1 regulator uses two LDOs and a charge pump. This regulator is used by Robin RF ASIC (VR1B) and synthesizer circuits (VR1A).

VR2 is a linear regulator used to supply Robin RF ASIC and the detector circuitry.

VR3 is a linear regulator used by Robin RF ASIC and VCTCXO circuitry.

VR4 is a linear regulator used by the PLL and UHF VCO circuitry.

VR5 is a linear regulator used by the Batman RFIC and the Alfred RF ASIC.

VR6 is a linear regulator used by Robin RF ASIC and TX LO buffer.

VR7 is a linear regulator used by Batman RF ASIC.

IPA1 and IPA2 are programmable current generators. The 27k Ohm external resistor is used to improve the accuracy of output current. IPA1 is used by lower band PA and IPA2 is used by higher band PA.

RF Interface

UEM handles the interface between the baseband and the RF section. It provides A/D and D/A conversion of the in-phase and quadrature receive and transmit signal paths, and also A/D and D/A conversions of received and transmitted audio signals to and from the UI section. The UEM supplies the analog AFC signal to the RF section according to the UPP DSP digital control. It also converts PA temperature into real data for the DSP.

Charging Control

The CHACON block of UEM asics controls charging. Needed functions for charging controls are pwm-controlled battery charging switch, charger-monitoring circuitry, battery voltage monitoring circuitry and RTC supply circuitry for backup battery charging. In addition, external components are needed for EMC protection of the charger input to the baseband module. The DCT4 baseband is designed to electrically support both DCT3 and DCT4 chargers.

Digital Interface

Data transmission between the UEM and the UPP is implemented using two serial connections, DBUS (9.6 MHz) for DSP and CBUS (1.2 MHz in CDMA) for MCU. UEM is a dual-voltage circuit: the digital parts are running from 1.8V and the analog parts are running from 2.78V. Vbat (3,6V) voltage regulators inputs also are used.

Audio Codec

The baseband supports two external microphone inputs and one external earphone output. The inputs can be taken from an internal microphone, from a headset microphone, or from an external microphone signal source through a headset connector. The output for the internal earpiece is a dual-ended type output, and the differential output is capable of driving 4Vpp to the earpiece with a 60 dB minimum signal to total distortion ratio. Input and output signal source selection and gain control is performed inside the UEM ASIC according to control messages from the UPP. Both a buzzer and an external vibra alert control signals are generated by the UEM with separate PWM outputs.

UI Drivers

There is a single output driver for buzzer, vibra, display, and keyboard LEDs inside UEM. These generate PWM square wave to devices.

AD Converters

There is an 11-channel analog-to-digital converter in UEM. The AD converters are calibrated in the production line.

BB-RF Interface Connections

All the signal descriptions and properties in the following tables are valid only for active signals.

Table 1: PDM Interface

Signal name	From	To	Parameter	Min	Typ	Max	Unit	Function
RX_IF_AGC	UPP GenIO 9	Batman	Voltage Min	0.0		0.1	V	Controls gain of VGA r in receiver
			Max	1.75	1.8	1.86		
			Clk Rate ⁽¹⁾		9.6	19.2	MHz	
TX_IF_AGC	UPP GenIO 7	Robin	Voltage Min	0.0		0.1	V	Controls gain of VGA in IF VGA in Robin
			Max	1.75	1.8	1.86		
			Clk Rate ⁽¹⁾		9.6	19.2	MHz	
TX_RF_AGC	UPP GenIO 26	Robin	Voltage Min	0.0		0.1	V	Controls gain of TX driver in Robin
			Max	1.75	1.8	1.86		
			Clk Rate ⁽³⁾		9.6	19.2	MHz	
PA_GAIN	UPP GenIO 11	Robin	Voltage Min	0.0		0.1	V	Controls gain of PA
			Max	1.75	1.8	1.86		
			Clk Rate ⁽³⁾		9.6	19.2	MHz	

Table 2: General I/O Interface

Signal name	From	To	Parameter	Input characteristics	Function
TX_Gate	UPP Gen IO 8 pullup	Robin	“1” Transmitter Off “0” Transmitter On Timing Accuracy	1.38 V 1.88 V 0.4 V 4 chips, and can be up to a total of 255 chips	Punctures the PA’s and the Robin ASIC Digital Into RF
PA_Boost	UPP Gen IO 03 pullup	Snapper Shark	“1” boost mode “0” data mode Timing Accuracy	1.38 V 1.88 V 0.4 V 4 chips, and can be up to a total of 255 chips	Sets PA current for desired linearity Digital Into RF
FAST_AGC	UPP Gen IO 13 pullup	Robin	“1” AMPS mode “0” CDMA mode	1.38 V 1.88 V 0.4 V 4 chips, and can be up to a total of 255 chips	Sets phone mode of operation AMPS or CDMA Digital into RF
SYNTH_LE	UPP Gen IO 25 pullup	Synthesizer	“1” Enable “0” Disable	1.38 V 1.88 V 0.4 V 4 chips, and can be up to a total of 255 chips	Latch enable for synthesizer Digital into RF

Table 3: VCTCXO Interface

Signal name	From	To	Parameter	Min	Typ	Max	Unit	Function
CLK192M_UPP	VCTCXO	Upp Batman Robin UHF PLL	Frequency		19.2		MHz	High stability clock signal for logic circuits, AC coupled sinewave. Analog Out of RF
			Signal amplitude	0.5	1.0	1.5	- Vpp	
AFC	UEM	VCTCXO	Voltage Min	0.0		0.1	V	Automatic frequency control signal for VCTCXO Digital Into RF
			Max	2.4		2.55		
			Settling time ⁽⁴⁾			0.2	ms	

Table 4: Regulated Supplies from UEM to RF

Signal name	From	To	Parameter	Min	Typ	Max	Unit	Function
VBAT	Battery	PA & UEM, external driver amps	Voltage	3.2	3.5	5.1	V	Battery supply. Lower limit is to guarantee regulator PSRR
			Current	0		2A peak		
VR1A	UEM	UHF Synth	Voltage	4.6	4.75	4.9	V	Charge pump + linear regulator.
			Current	0	4	5	mA	
VR1B	UEM	PA Iref current sources in Robin	Voltage	4.6	4.75	4.9	V	Charge pump + linear regulator
			Current	0	4	5	mA	
VR2	UEM	Robin driver amps	Voltage	2.70	2.78	2.86	V	Linear regulator
			Current			100	mA	
VR3	UEM	VCTCXO Robin VHF synthesizer	Voltage	2.70	2.78	2.8	V	Low noise linear regulator for VCTCXO
			Current			20	mA	
VR4	UEM	UHF VCO, synthesizer	Voltage	2.70	2.78		V	Low Iq linear regulator
			Current				mA	
VR5	UEM	Batman IF, BB, LNA, mixer	Voltage	2.70	2.78		V	Low Iq linear regulator
			Current				mA	
VR6	UEM	Robin IF, BB, mixers	Voltage	2.70	2.78		V	Low Iq linear regulator
			Current				mA	
VR7	UEM	Batman VHF synthesizer	Voltage	2.70	2.78		V	Low noise linear regulator for synthesizer
			Current				mA	
VREFRF01	UEM	Batman Vref	Voltage	1.334	1.35	1.366	V	Voltage Reference for RF-IC 1.2% accuracy

Table 4: Regulated Supplies from UEM to RF

Signal name	From	To	Parameter	Min	Typ	Max	Unit	Function
VREFRF02	UEM	Robin Vref	Voltage	1.334	1.35	1.366	V	Voltage Reference for RF-IC 1.2% accuracy
VIO	UEM	Digital IO + PLL digital	Voltage ----- Current	1.70 -----	1.8	1.88 ----- 50	V ----- mA	Supply for RF-BB digital interface and some digital parts of RF.

Table 5: Slow A/D Converters

Signal name	From	To	Parameter	Min	Typ	Max	Unit	Function
PA_TEMP	Thermistor	UEM	Input voltage range ----- Input clock freq	0 -----	-----	2.741 ----- 2.5	V ----- MHz	PA temperature sensor output voltage Analog Out of RF
PWROUT	Robin	UEM	Input voltage range ----- Input clock freq	0 -----	-----	2.741 ----- 2.5	V ----- MHz	Buffered output of TX output detector and TX power supply Analog Out of RF
FALSE_DET	Robin	UEM	Input voltage range ----- Input clock freq	0 -----	-----	2.741 ----- 2.5	V ----- MHz	protection circuit that is independent of main transmitter on-off control circuit and minimizes the possibility of false transmission caused by component failure

Table 6: RF-BB Analog Signals

Signal name	From	To	Parameter	Min	Typ	Max	Unit	Function
RX_IP_RF RX_IN_RF RX_QP_RF RX_QN_RF	Batman	UEM	Differential voltage swing (static) ----- DC level ----- Input Bandwidth	1.35 ----- 1.3 -----	1.4 ----- 1.35 -----	1.45 ----- 1.4 ----- 615	Vpp ----- V ----- kHz	Differential in-phase and quadrature RX baseband signal Analog Out of RF
TX_IP_RF TX_IN_RF TX_QP_RF TX_QN_RF	UEM	Robin	Differential voltage swing (static) ----- DC level ----- -3 dB Bandwidth	----- 1.65 ----- 650	0.9 ----- 1.7 -----	1.0 ----- 1.75 ----- 1950	Vpp ----- V ----- kHz	Differential quadrature phase TX baseband signal for RF modulator Analog into RF

Table 7: RFIC Control

Signal name	From	To	Parameter	Min	Typ	Max	Unit	Function
RF_BUS_CLK RF_BUS_DATA RF_BUS_EN1X	UPP	Robin/Batman/ PLL	High-level input voltage, V _{IH}	1.2	1.3	2.35	V	Serial Clock = Digital Into RF
			Low-level input voltage, V _{IL}			0.5	V	Bidirectional Serial Date = Digital I/O
			High-level output voltage, V _{OH}	1.3	1.4	2.45	V	Latch enable for Batman and Robin = Digital Into RF
			Low-level output voltage, V _{OL}			0.4	V	
			Clock		9.72		MHz	
SYNTH_LE	UPP	PLL	Voltage	0		1.8	V	Synthesizer latch enable
			Timing resolution			10	us	

Table 8: RFIC Control

Signal name	From	To	Parameter	Min	Typ	Max	Unit	Function
PURX	UEM	Robin/Batman	Voltage Level	0		1.8	V	Power Up Reset for Batman and Robin
			Timing resolution			10	us	

UPP

UPP Introduction

RH-17 uses UPP8Mv2.2 ASIC. The RAM size is 8Mbit. The UPP ASIC is designed to operate in a DCT4 engine, and is designed as part of the DCT4 common baseband task force. The DCT4 processor architecture consists of both DSP and MCU processors.

Blocks

UPP is internally partitioned into two main parts: the Brain and the Body.

The Brain consists of the Processor and Memory System (*i.e.*, Processor cores, Mega-cells, internal memories, peripherals and external memory interface). The following blocks are included: the DSP Subsystem (DSPSS), the MCU Subsystem (MCUSS), the emulation control EMUCTl, the program/data RAM PDRAM, and the Brain Peripherals–subsystem (BrainPer).

The Body consists of the NMP custom cellular logic functions. These contain all interfaces and functions needed for interfacing with other DCT4 baseband and RF parts. It includes the following sub-blocks: MFI, SCU, CTSI, RxModem, AcclF, UIF, Coder, GPRSCip, BodyIF, SIMIF, PUP and CDMA (Corona).

Flash Memory

Introduction

Flash memory is a high-performance, 64-Mbit, single power supply 1.8 Volt-only FLASH memory device. This device is designed to be programmed in-system with the standard system 1.8-volt Vcc supply. A 12.0 volt Vpp is not required for program or erase operations, although an acceleration pin is available if faster write performance is required. The device is a boot-sectored device, consisting of eight 8Kb and 63 sectors of 64Kb each.

The device has two read modes: asynchronous read and burst mode read. Device powers-up in an asynchronous read mode. In the asynchronous mode, the device has two control functions which must be satisfied in order to obtain data at the outputs. In the linear mode, the device will deliver a continuous sequential word stream starting at the specified word and continuing until the end of the memory or until the user loads in a new starting address or stops the burst advance. The burst mode read operation is a synchronous operation tied to the rising edge of the clock. The microprocessor supplies only the initial address; all subsequent addresses are automatically generated by the device at the rising edge of subsequent clock cycles. The burst read cycle consists of an address phase and a corresponding data phase. The device also is capable of Burst Suspend and Burst Resume operations.

In order to reduce the power consumption on the bus, a Power Save function is introduced. This reduces the amount of switching on the external bus.

User Interface Hardware

LCD

Introduction

RH-17 uses a 96x65 monochrome display. Dimensions for the display are 38.4 mm x 37.6 mm x 1.6 mm, with an active area of 31.15 mm x 24.78 mm.

Interface

LCD is controlled by UI SW and control signals.

Booster capacitor (C302 1uF) is connected between booster pin (Vout) and ground. The capacitor stores boosting voltage.

Keyboard

Introduction

RH-17 keyboard design is Nokia Jack style, with up and down navigation keys, two soft keys, 12 number keys. The PWR key is located on top.

Power Key

All signals for keyboard are coming from UPP asic except pwr key signal which is con-

nected directly to UEM. Pressing of pwr key is detected so that switch of pwr key connects PWONX is of UEM to GND and creates an interrupt.

Keys

Other keys are detected so that when a key is pressed down, the metal dome connects one S-line and one R-line of UPP to GND and creates an interrupt for SW. Matrix of how lines are connected and which lines are used for different keys is described in the following table. S-line S0 and R-line R5 are not used.

Returns / Scans	S1	S2	S3	S4
R0	NC	Send	End	NC
R1	Soft left	Up	Down	Soft right
R2	1	4	7	*
R3	2	5	8	0
R4	3	6	9	#

NC = Not Connected

Lights

Introduction

RH-17 has seven white LEDs for lighting purposes: four (V300, V301, V302, V303) are for keyboard (typeLWL88S) and three (V304, V305, V306) are for display (type LWY87). LED type is white-light emitting diode.

Interfaces

Display keyboard lights are controlled by UEM Klight signal (8-bit register DriverPWMR, bits 7...4). Klight output is turned ON, which controls the LED driver (LM2795B) used to control the current going through the LEDs. A constant current source is used to ensure that the LEDs provide uniform intensity and color.

Technical Information

LEDs have white plastic body around the diode itself, which directs the emitted light to UI side. Current for keypad lights is limited by resistor between Vbatt and LEDs.

Vibra

Introduction

Vibra is located on the D-cover and is connected by spring connectors on the PWB. It is located in the left bottom side of the engine.

Interfaces

Vibra is controlled by pwm signal VIBRA from UEM. This signal allows control of both

frequency and pulse width of signal. Pulse width is used to control current when battery voltage changes. Frequency control searches for optimum frequency to ensure silent and efficient vibrating.

Parameter	Requirement	Unit
Rated DC Voltage	1.3	V
Rated speed	9500 ±3000	rpm
Rated current	115 ±20	mA
Starting current	150 ±20	mA
Armature resistance	8.6	ohm
Rated DC voltage available	1.2 to 1.7	V
Starting DC voltage	min. 1.2	V

Audio Hardware

Earpiece

Introduction

The 13 mm speaker capsule that is used in DCT3 products also is used in RH-17.

The speaker is dynamical—very sensitive, and capable of producing relatively high sound pressure at low frequencies. The speaker capsule and surrounding mechanics comprise the earpiece.

Microphone

Introduction

The microphone is an electric microphone with omnidirectional polar pattern. It consists of an electrically polarized membrane and a metal electrode, which form a capacitor. Air pressure changes (*i.e.*, sound) move the membrane, which causes voltage changes across the capacitor. Since the capacitance is typically 2 pF, a FET buffer is needed inside the microphone capsule for the signal generated by the capacitor. The microphone needs bias voltage as a result of the FET.

Battery

Phone Battery

Introduction

An 850 mAh Li-ion battery (BL-5C) is standard in RH-17.

Interface

The battery block contains NTC on phone and BSI resistors for temperature measurement

and battery identification. The BSI fixed resistor value indicates the chemistry and default capacity of a battery. NTC resistor measures the battery temperature. Temperature and capacity information is needed for charge control. These resistors are connected to the BSI battery connector and the NTC is connected to BTEMP pins of UEM. Phone has pull-ups on these lines so that they can be read by A/D inputs in the phone (see the following figure). Resistors on phone are ESD protection. There also are spark caps in the BSI line to prevent ESD.

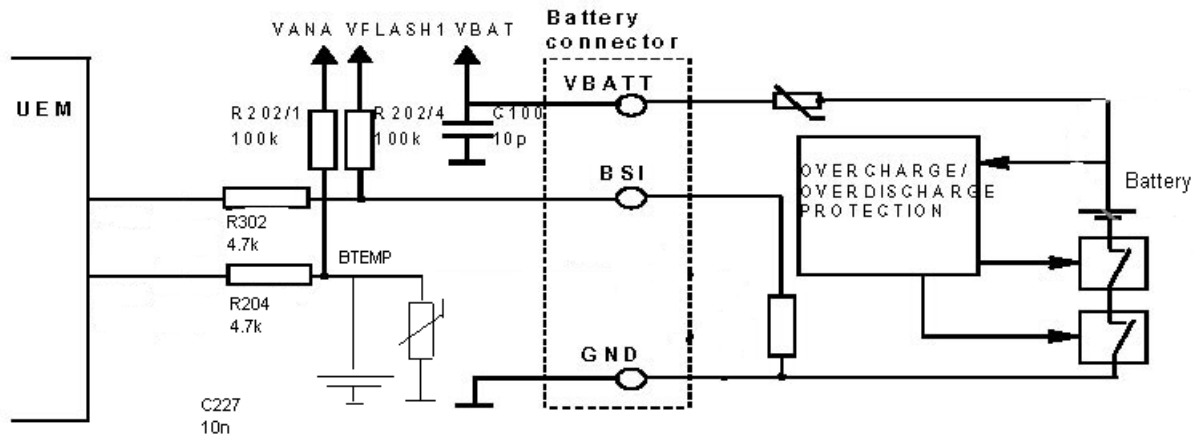

Batteries have a specific red line to indicate if the battery has been subjected to excess humidity. The batteries are delivered in a "protection" mode, which gives longer storage time. The voltage seen in the outer terminals is zero (or floating), and the battery is activated by connecting the charger. Battery has internal protection for overvoltage and overcurrent.

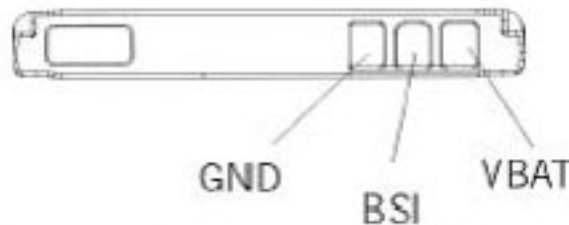

Figure 2: Connector order for Lynx batteries

Battery Connector

RH-17 uses a spring-type battery connector. This makes the phone easier to assemble in production and ensures a more reliable connection between the battery and PWB.

#	Signal name	Connected from - to	Batt. I/O	Signal properties A/D--levels--freq./timing	Description / Notes
1	VBAT	(+) (batt.)	VBAT	I/O	Vbat
2	BSI	BSI (batt.)	UEM	Out	Ana.
3	GND	GND	GND		Gnd

Accessories Interface

System connector

Introduction

RH-17 uses the Tomahawk accessories via the Tomahawk connector.

Interface

Tomahawk bottom connector consists of charging plug socket and Tomahawk System connector (see figures that follow). Minimum configuration of Tomahawk interface includes charging, mono audio, power out, ACI and Fbus. USB and stereo audio out are optional.

Tomahawk system connector includes:

- **Charging**
 - Pads for 2 -wire charging in cradles
- **Audio (Stereo audio optional)**
 - FM radio antenna connection (may be option with accessory)
 - 2-wire differential mic input
- **Power out**
 - 2.78V 70 mA output to accessories (bb4.0, bb4.5)
 - 2.5V 90 mA output to accessories (bb5.0)
- **Detection/controlling**
 - ACI
 - Point to point bi-directional data line
- **USB (Optional)**
 - Power in 5V in from USB host
 - USB v2.0 device mode (Full speed 12M)
- **Fbus**
 - Standard Fbus

AT command mode (Nokia Serial Bus)

Phonet message mode

Fast Fbus, fast data bus to add on modules

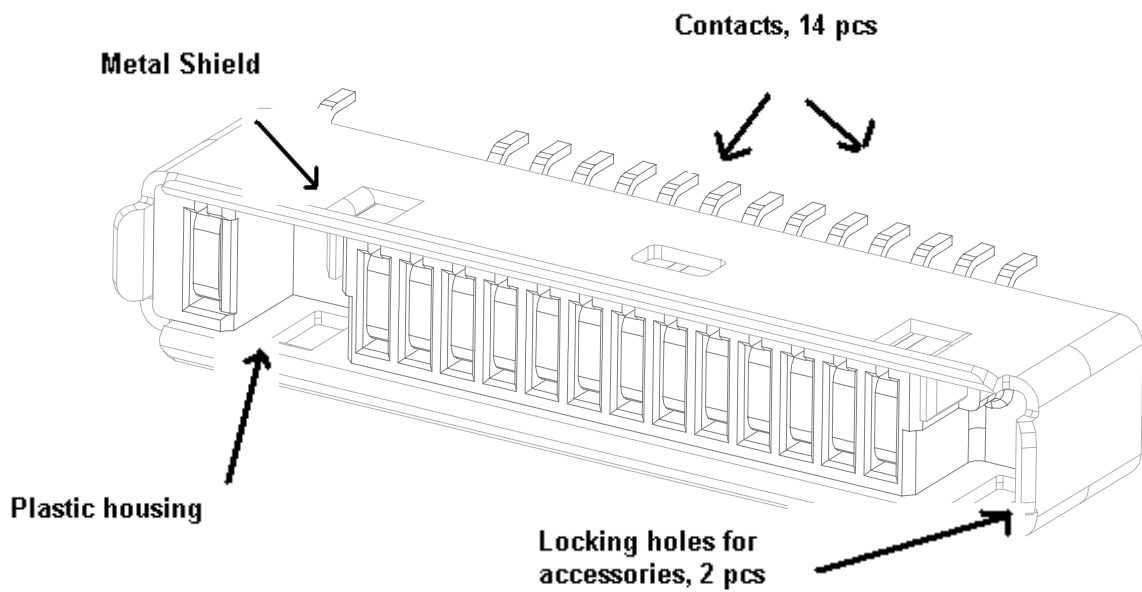

Figure 3: Tomahawk system connector

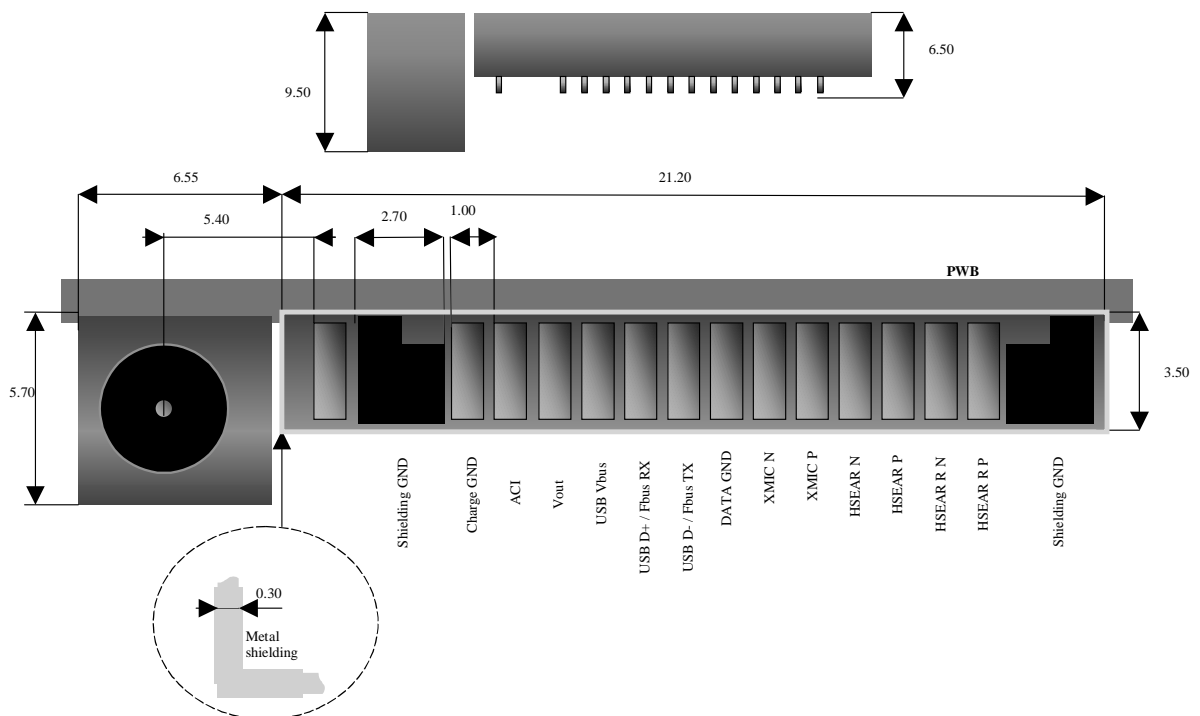

Figure 4: Mechanical dimensions and signals of Tomahawk bottom connectors

An accessory is detected by the ACI-line. All accessories will generate interrupt while inserted or removed from the phones Tomahawk system connector. Insertion of an accessory will generate HEADINT interrupt by pulling ACI line down. Vout is enabled by UPP. The MBUS line is connected to HEADINT line. If HEADINT interrupt from low to high transition occurs within 20msec a more advanced accessory is connected else a basic headset is connected. The accessory flowchart outlines the routines used for all accessory detection.

The following diagram illustrates accessory detection / external audio flowchart.

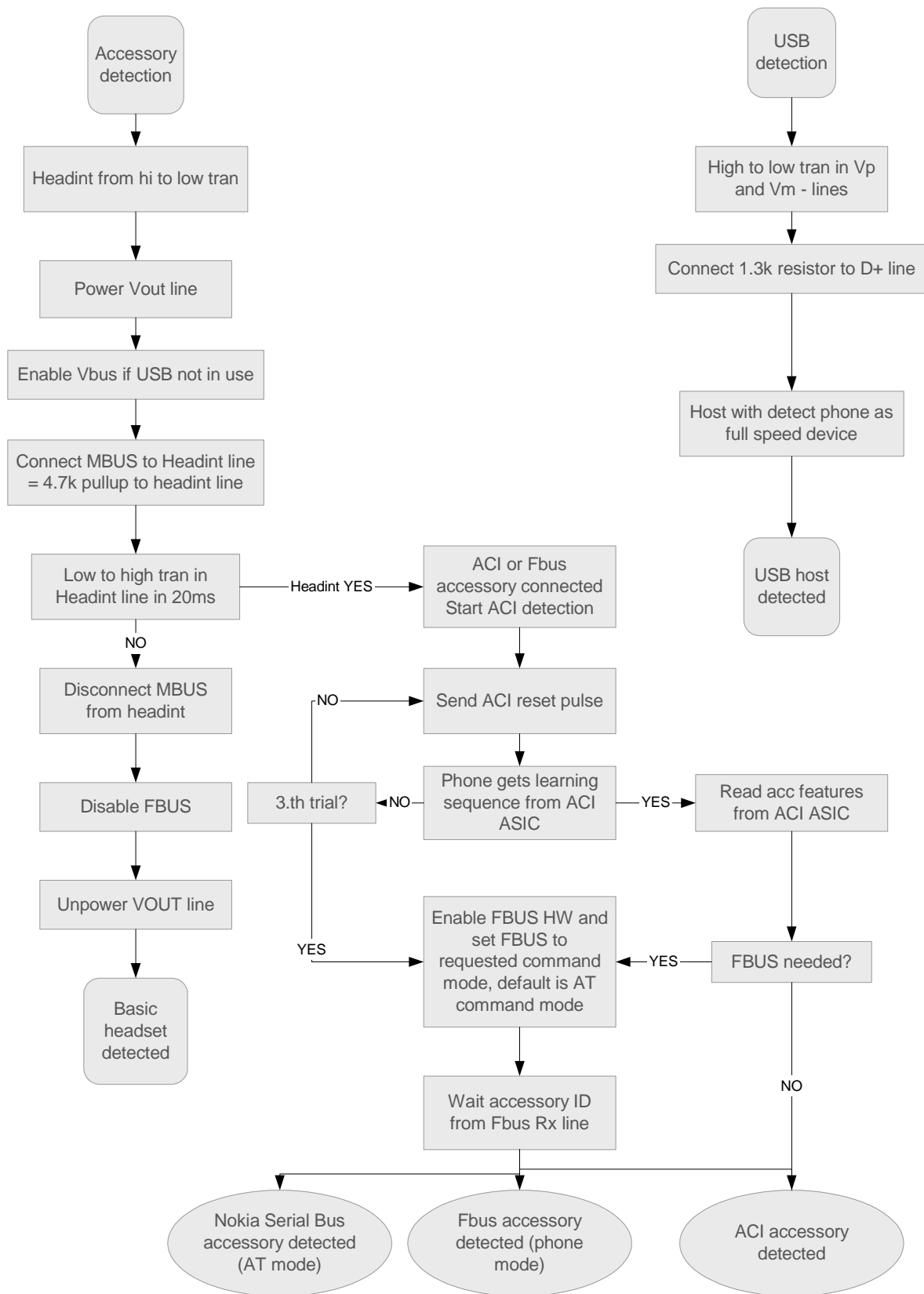

Figure 5: Accessories Detection Flowchart

TTY/TTD and Universal Headset Jack

TTY/TTD devices use standard 2.5 mm 3-pin plug (tip = transmit, ring = receive, sleeve = ground) while universal headset also uses same type of plug (tip = microphone, ring = earpiece, sleeve = ground). Since only three pins are available for both transmit and receive at same time, both paths have to use single-end design (share the ground). The detection scheme for this interface uses a built-in normally closed switch in the universal headset jack. When there is no device being plugged in, the switch is closed which forces the level on the detection line (GENIO(12)) to 1.8V. When a device is plugged in, the voltage is set to 0V. The detection line then can identify whether a device is plugged in or not.

Charger IF

Introduction

The charger connection is implemented through the bottom connector. DCT-4 bottom connector supports charging with both plug chargers and desktop stand chargers.

There are three signals for charging. Charger gnd pin is used for both desktop and for plug chargers as well as charger voltage. PWM control line, which is needed for 3-wire chargers, is connected directly to gnd in module PWB so the RH-17 engine doesn't provide any PWM control to chargers. Charging controlling is done inside UEM by switching UEM internal charger switch on/off.

Interface

The fuse F100 protects from high currents (e.g., when broken or pirate chargers are used). L100 protects engine from RF noises, which may occur in charging cable. V100 protects UEM ASIC from reverse polarity charging and from high charging voltage. C106 is also used for ESD and EMC protection.

Test Interfaces

Production Test Pattern

Interface for RH-17 production testing is 5-pin pad layout in BB area (see figure below). Production tester connects to these pads by using spring connectors. Interface includes MBUS, USRX, FBUSTX, VPP, and GND signals. Pad size is 1.7mm. The same pads also are used for AS test equipment such as module jig and service cable.

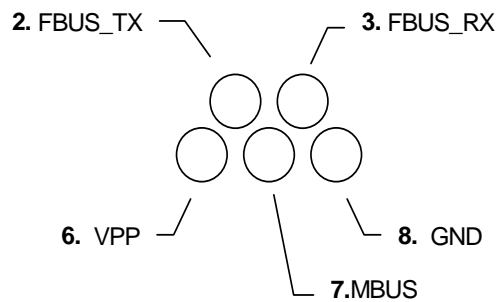

Other Test Points

BB ASICs and flash memory are chip scale package (CSP) components and the visibility is very poor. This makes measuring of most of the BB signals impossible. In order to debug BB at least at some level, the most important signals can be accessed from test points. The figures below show test points throughout the PWB for all critical signals.

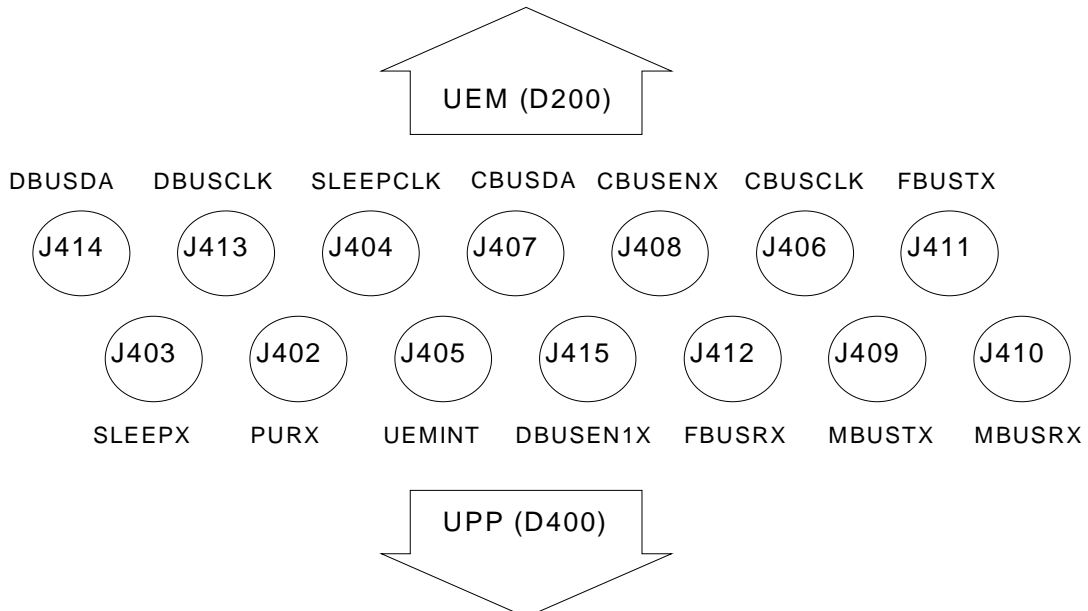

EMC

General

EMC performance of the RH-17 baseband is improved by using ESD components: V101, L103, L104, R105, R112, R113, Z300, and spargaps to protect UEM, UPP, and Flash. UEM has internal protection against +/-8kV ESD pulse.

BB Component and Control I/O Line Protection

Keyboard Lines

ESD protection for the keyboard is provided by component Z300. The device is designed to reduce EMI and RFI noise. In addition, this integrated device includes ESD protection circuitry that will protect the phone's ASICs from destruction when subjected to ESD surges up to 15kV.

PWB

All edges are grounded from both sides of PWB and solder mask is opened from these areas. Target is that any ESD pulse faces ground area when entering the phone (e.g., between mechanics covers).

LCD

ESD protection for LCD is implemented by connecting metal frame of LCD to gnd. Connection is only on one side, at the top of the LCD, and that is not the best solution. Due to SAR issues, the C-cover metallization is cut in the middle, just under the display, making the whole engine more sensitive to ESD. Software protects against LCD crashing.

Microphone

Microphone is an unsymmetrical circuit, which makes it well protected against EMC.

EARP

EARP is protected with the R170 dual package varistor.

Bottom Connector Lines

XMICP, XMICN, XEARP, XEARN lines have varistors R105 and R112, as well as the EMI filters L103 and L104.

Hookint has same protection as XMICP and HeadInt has RC-circuit protection.

Charger + is protected with a ferrite bead (42W/100MHz) and capacitor to ground (1n).

Charger - is connected to GND.

Battery Connector Lines

BSI is protected with spark gaps and RC circuit (47k & 10n) where resistors are size 0603.

M-bus F-bus

ESD protection for M-bus and F-bus is done with spargaps and an ESD ASIC (V201).

General Information About Testing

Phone operating modes

Phone has three different modes for testing/repairing phone. Modes can be selected with suitable resistors connected to BSI- and BTEMP- lines as follows:

Mode	BSI- resistor	BTEMP- resistor	Remarks
Normal	68k	47k	
Local	3.3K ohms	47k ohms	
Test	6.8k ohms	47k ohms	Recommended with base-band testing. Same as local mode, but making a phone call is possible.

The MCU software enters automatically to local or test mode at start-up if corresponding resistors are connected.

Note! Baseband doesn't wake up automatically when the battery voltage is connected (normal mode).

Power can be switched on by

- pressing the PWR key
- connecting a charger
- RC-alarm function

In the local and test mode, the baseband can be controlled through MBUS or FBUS (FBUS is recommended) connections by Phoenix service software.

RF Module

Requirements

The RH-17 RF module supports CDMA800 as described in:

- IS2000-2-A Physical Layer Standard for cdma2000 Spread Spectrum Systems; and
- IS-98D (Draft 4) Recommended Minimum Performance Standard for Spread Spectrum Mobile Stations.

Temperature Conditions

Surface temperature (SPR5 - Product Safety)

Maximum temperature rise is 50° C for nonmetallic surfaces and 30° C for metal surfaces at room temperature.

Other temperature requirements (SPR4 - Operating Conditions)

Meeting requirements: -30...+ 60° C

Storage requirements: -30...+85° C

Main Technical Characteristics

Environmental Specifications

Normal and extreme voltages

Voltage range:

- nominal battery voltage: 3.6 V
- maximum battery voltage: 4.2 V
- minimum battery voltage: 3.2 V

Temperature conditions:

- ambient temperature: -30...+ 60° C
- PWB temperature: -30...+85° C
- storage temperature range: -40 to +85° C

Antenna

A single-band, whip antenna/internal antenna combination is used.

Transmitter

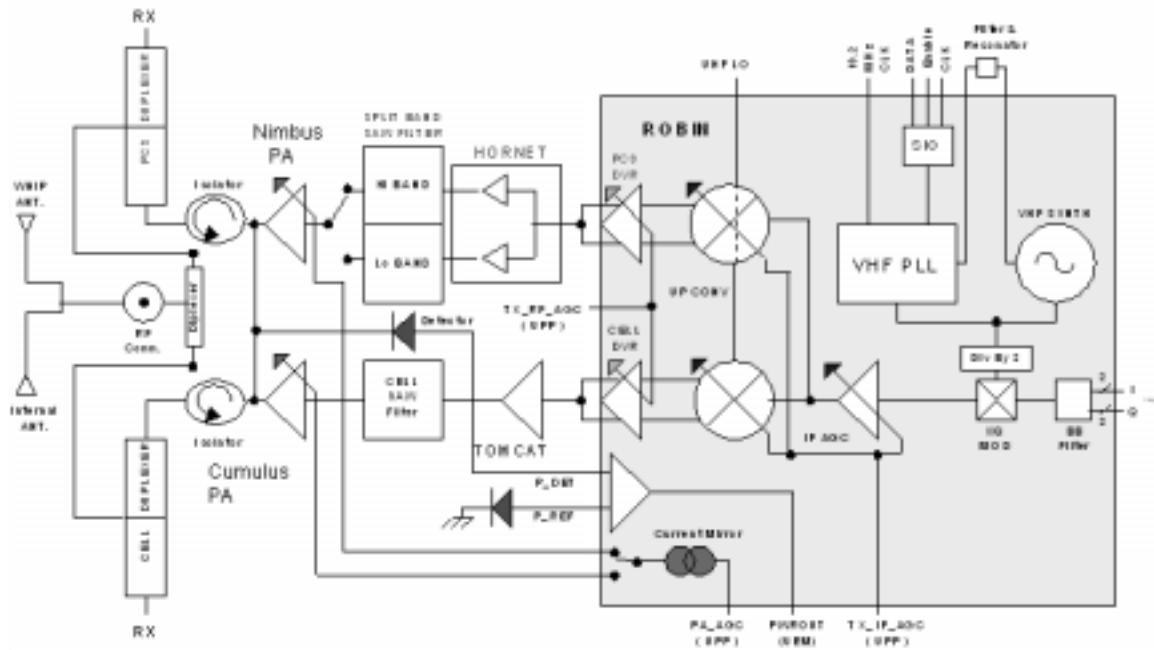

Figure 6: Trimode block diagram

The transmit chain up to the RF driver stage is integrated into one transmit-integrated circuit called Robin, with external power amplifiers (PA). The channel spacing is 50 kHz.

All data transmitted on the channel is convolutionally encoded and block-interleaved. Modulation is 64-ary orthogonal (RC1 and RC2) and direct sequence spread by a quadrature pair of PN sequences at a fixed chip rate. The data is filtered, O-QPSK modulated and up-converted to the appropriate transmission frequency. RC3 and RC4 use HPSK modulation at data rates up to 153.6 kbps (RC3) and 115.2 kbps (RC4).

The baseband I/Q signals are converted to IF frequency in the I/Q modulator by Quadrature mixing. The modulated IF signals go through a variable gain amplifier (IF AGC) and then are routed to the TX path. The path consists of an upconverter and a variable gain RF amplifier. The IF signal is converted up to RF with a differential output upconverter and then fed to the RF amplifier. The RF amplifier has variable gain capability (RF AGC) with up to 40 dB of dynamic gain control.

The outputs of the RF amplifiers are differential. The differential outputs from Robin are combined into single-ended output by an external balun and fed into an external driver amplifier module (Tomcat).

The output of the Tx saw filter is connected to the PA. Out of the PA is an isolator, then the antenna.

The PA modules contain all the necessary matching networks and reference current circuitry for variable gain control and biasing ON/OFF. A variable reference current is used to vary the PA gain and PA bias current. The variable gain technique reduces PA current consumption and improves the signal-to-noise ratio at low output power levels. The precision bias current (and gain) control is achieved by varying the PA reference current

with a PDM control voltage.

The transmitter chain utilizes smart power techniques and only the required circuits are powered at the appropriate times. In order to save energy in puncture mode, when there is no speech activity during a call, the driver and power amplifiers and the Robin IC are switched ON and OFF rapidly. These units also are in the OFF state when the transmitter is in standby. The ON/OFF switch commands are issued by a Digital ASIC (UPP). The UPP's PDM controls a current mirror in Robin that provides the PA reference current. Switching each reference current ON/OFF switches each PA ON/OFF. The VHF synthesizer and power detector circuits are left on during the puncture mode.

Synthesizer

Refer to Figure 6 for a block diagram that illustrates all three synthesizers and how they interconnect in the system.

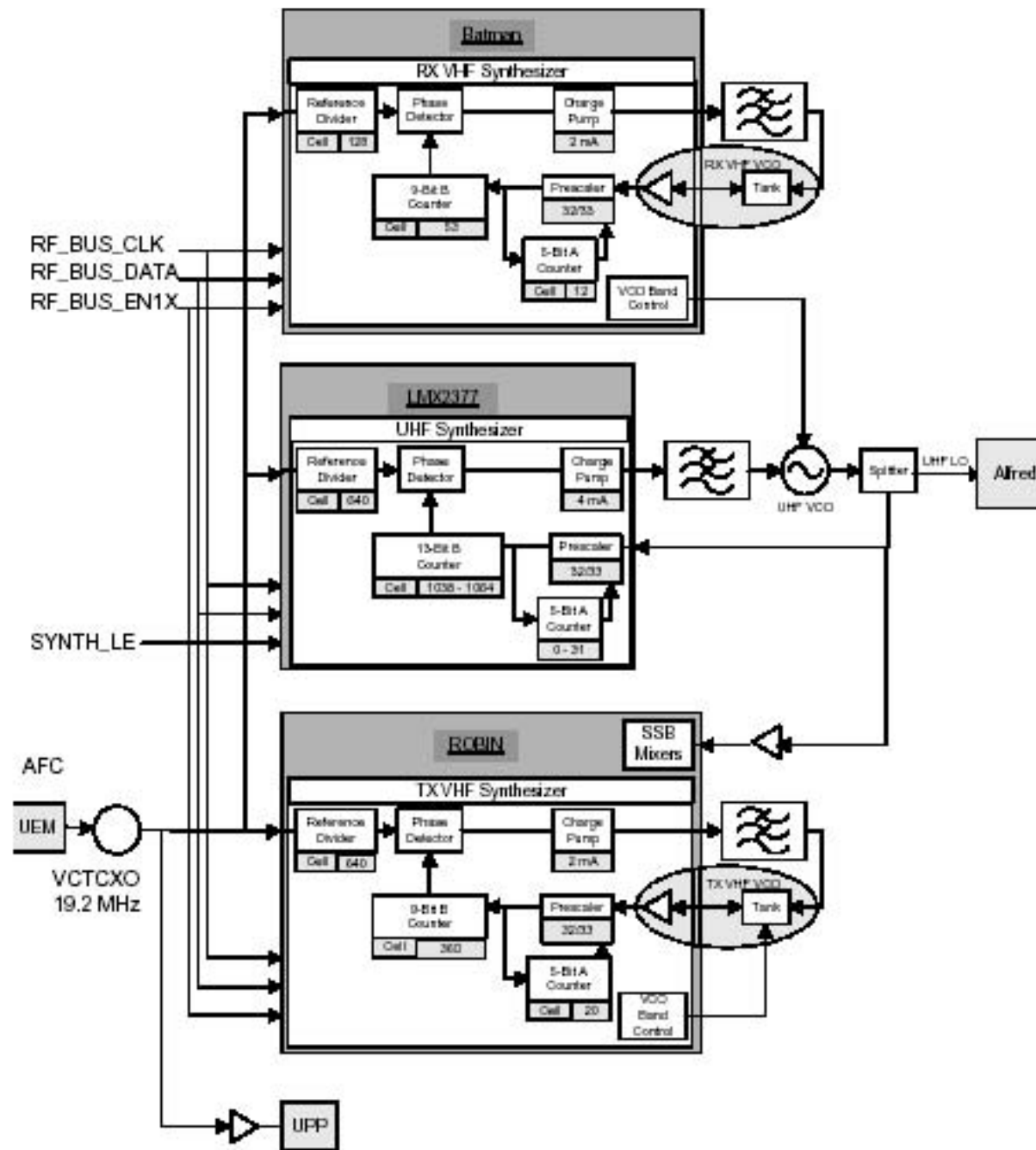

Figure 7: Synthesizer System Block Diagram

UHF LO Synthesizer

The UHF LO synthesizer generates the first RX LO frequency for the receiver (down-conversion) and the second TX LO frequency for the transmitter (up-conversion). The synthesizer is a dual-modulus prescaler type and utilizes a phase-frequency detector with a charge pump that sinks or sources currents, depending upon the phase difference between the phase detector input signals.

For the cellular AMPS/CDMA band, channel spacing is 30 kHz. An external buffer is provided for high isolation between Robin and the VCO to reduce VCO pulling due to chang-

ing load.

1st TX VHF LO Synthesizer (Robin)

The TX VHF Synthesizer is integrated within the Robin RFIC and generates the LO signals for the IQ-modulator in Robin. The synthesizer has an internal VCO with an external resonator. The VCO operates at two times the CELL IF frequencies. A band-switch signal, VCO_Band, is used to shift the center frequency of the external resonator.

The synthesizer is a dual-modulus prescaler type, and utilizes a phase detector with a charge pump that sinks or sources currents, depending on the phase difference between the detector input signals. The width of the pulses depends on the phase difference between the signals at input of the phase detector. The main divider, auxiliary divider, and reference divider are programmable through the serial interface to Robin.

The TX VHF Synthesizer generates 346.2 MHz for Cell Band.

The TX VHF Synthesizer comparison frequency for Cell Band is 30 kHz.

2nd RX VHF LO Synthesizer (Batman)

The RX VHF Synthesizer is integrated within the Batman RFIC and generates the LO signals for the IQ demodulator in Batman. The synthesizer has an internal VCO with an external resonator. The VCO operates at two times the common 128.1 MHz RX IF frequency. A band-switch signal, Band_Sel, is used to select the band of operation for the UHF VCO.

The synthesizer is a dual-modulus prescaler type, and utilizes a phase detector with a charge pump that signals or sources currents, depending upon the phase difference between the detector input signals. The width of the pulses depends on the phase difference between the signals at input of the phase detector. The main divider, auxiliary divider, and reference divider are programmable through the serial interface to Batman.

The RX VHF Synthesizer generates 256.2 MHz for Cell Band.

The RX VHF Synthesizer comparison frequency for Cell Band is 150 kHz.

VCTCXO - System Reference Oscillator

The VCTCXO provides the frequency reference for all the synthesizers. It is a voltage-controlled, temperature-compensated, 19.2MHz crystal oscillator that can be pulled over a small range of its output frequency. This allows for an AFC function to be implemented for any frequency accuracy requirements. This is done by DSP processing of received I/Q signals.

Closed loop AFC operation allows very close frequency tracking of the base station to be done in CDMA mode. This will enable the unit to track out aging effects and give the required center frequency accuracy in cellular bands.

The most practical way of clock distribution is driving all three chips (UHF PLL, Batman, and Robin) directly from the VCTCXO. A buffer is used to drive the UPP in order to isolate

the UPP's digital noise from the VCTCXO, which prevents contamination of the 19.2 MHz reference onto the PLL chips of the system. Since the VCTCXO output is a sinewave, such clock distribution will not cause any clock signal integrity problems, even for relatively long traces (what might occur in case of a digital square waveform with fast transition times). The VCTCXO output is AC, coupled to Batman, Robin, UHF PLL, and the digital ASICs (see figure) to eliminate DC incompatibility between those pins.

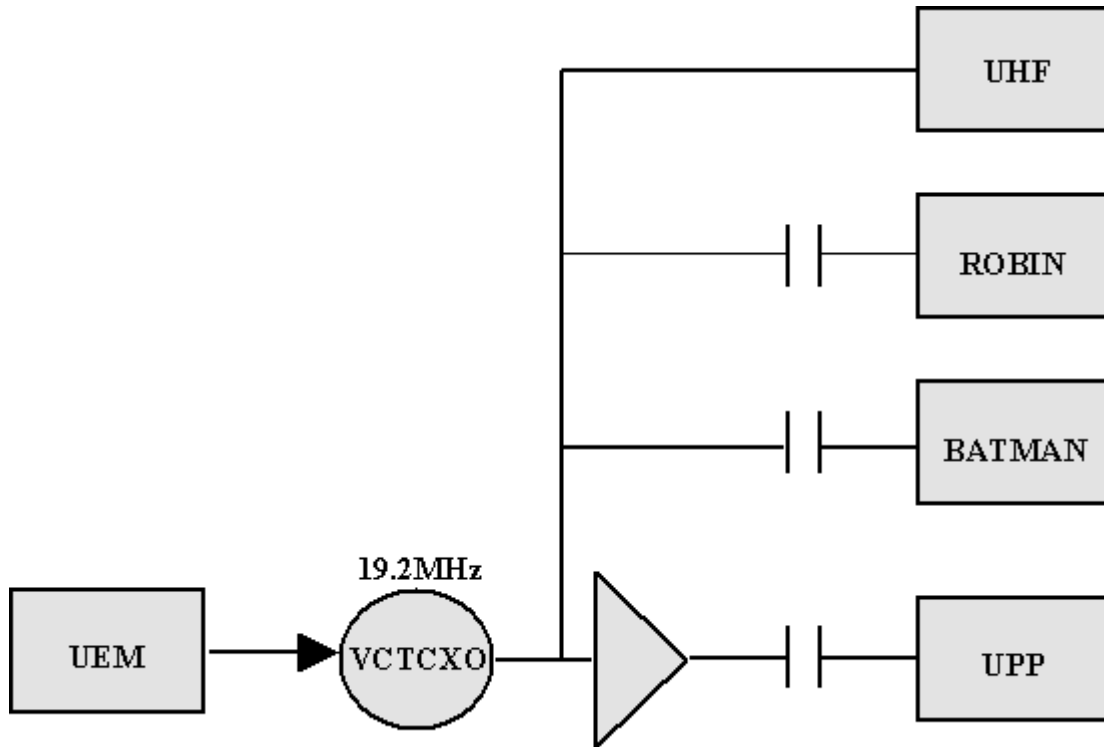

Figure 8: VCTCXO Clock Distribution

Receiver

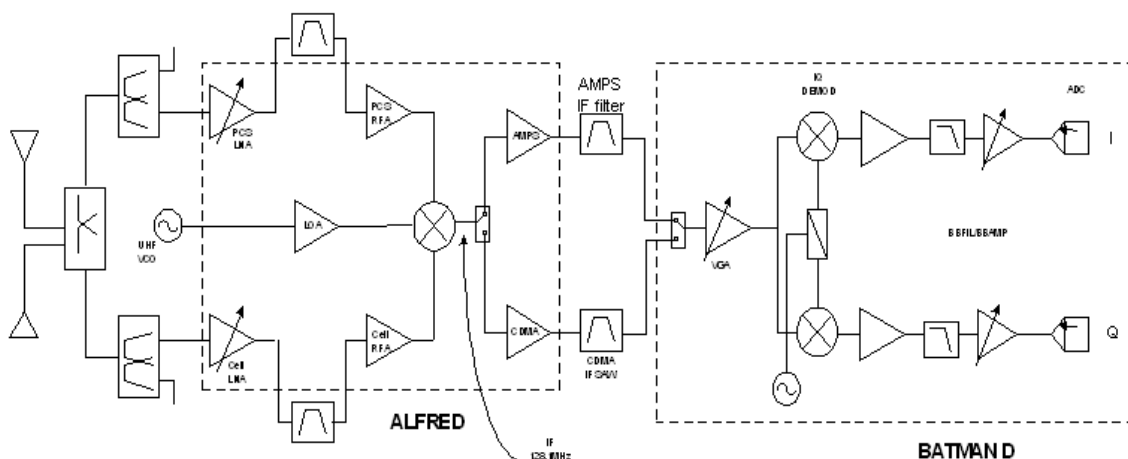

Figure 9: RH-17 Receiver Block Diagram

The receiver is a dual conversion I/Q receiver with a first IF of 128.1 MHz. The front-end RFIC (Alfred) contains a low noise amplifier (LNA), a radio frequency amplifier (RFA), a down-converter, an intermediate frequency amplifier (IFA), and a local oscillator amplifier (LOA). Between the LNA and the RFA is a bandpass filter which will reject out-of-

band spurious and act as image rejection. The IF filter is between the Alfred IC and the BatmanD IC. The purpose of this filter is to guarantee rejection in adjacent and alternate channels.

The RX IF ASIC BatmanD is used to convert the IF down to baseband I and Q. The ASIC contains a VGA section, IQ demodulator, baseband filters (BBFIL) for AMPS and CDMA. Switchable gain baseband amplifier (BBAMP), and RX VHF PLL. The I/Q BB signals are output to UEM chip for analog-to-digital conversion and further signal processing.

GE / CE Interface

The GE / CE interface has various control signals, a reference clock, a sleep clock, and serial bus. There also are V_{CORE} and V_{IO} voltage generated in the CE baseband used to power some of the GE.

Digital Supply Vio

This supply is used to power the GPS RF/BB interface lines and also to preserve configuration settings in the RFIC when it is in power-down mode. It originates from the CE energy management system.

Parameter	Units	Min	Typ	Max
On Level	V	1.65	1.8	1.95
Load Current - Active	mA		1.6	3
Load Current - Sleep	μ A		240	350

Digital Supply Vcore

This supply is used to power the internal GPS Baseband ASIC during operation and to preserve the internal state when it is in deep sleep mode. It originates from the CE energy management system.

Parameter	Units	Min	Typ	Max
On Level	V	1.425	1.5	1.65
Load Current - Active	mA		26	35
Load Current - Sleep	μ A		30	500

Digital GE/CE Interface Signal Parameters

Parameter	Units	Min	Typ	Max
Hi Level	Volts	$0.8 \cdot V_{IO}$		
Lo Level	Volts			$0.22 \cdot V_{IO}$

RF ASIC and LNA Supply V_{RF}

The V_{RF} supply is the main source of power for the RF IC. It originates in GPS baseband section and will be turned off for power-saving sleep modes.

Parameter	Units	Min	Typ	Max
On Level	V	2.7	2.8	3.3
Load Current - Active	mA		40	55

